

LP182*182-M-54-MH

Rated Power 410-415W



MBB Cell
New circuit design, lower internal current, lower internal resistance loss.



Higher Output Power
Module adopts 108 pcs of 182*182mm half cells, the maximum power can reach 415W.



Low Light Features
Higher performance under low light environment.



Load Capacity
Mechanical load tests including wind load 2400 Pa and snow load 5400 Pa done by TUV Nord.

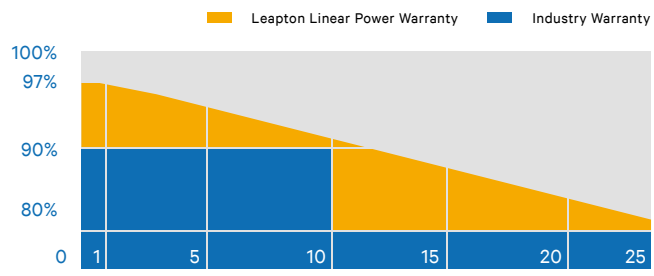

25 YEARS Product Warranty

25 YEARS Power Warranty



IEC 61215-2: 2016
IEC 61730-2: 2016

Headquarter : Leapton Energy Co., Ltd.

Tosei Bldg. 6F, 1-2-1 Aioi-cho, Chuo-ku Kobe-shi, Hyogo, 650-0025, Japan

+81-78-382-3182

www.leaptonenergy.jp

Manufacturer : Leapton Solar (Changshu) Co., Ltd.

No.9, Sunshine Avenue, Changshu City, Jiangsu, China

+86-512-88800068

info@leaptonenergy.com

www.leaptonpv.com

MECHANICAL DIAGRAMS

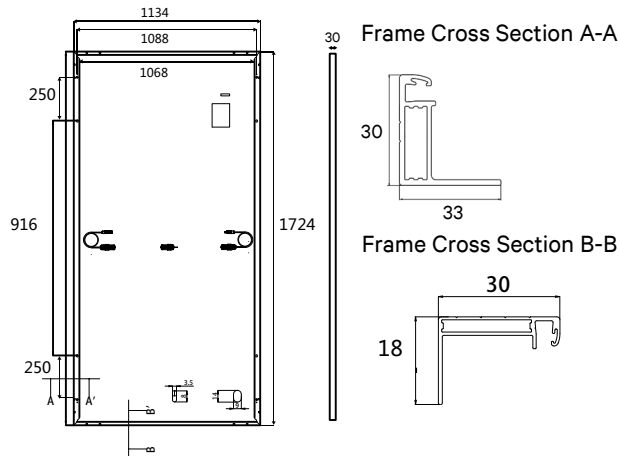

SPECIFICATIONS

Weight	21.5kg
Dimensions	1724mm*1134mm*30mm
Cell Dimensions	182*182mm
Maximum System Voltage	1500V
Junction Box	IP68
Frame	Aluminum Alloy
Cable	4mm ² , Landscape: N 1100mm/P 1100mm Portrait: N 200mm/P 300mm
Connector	PV-GZX 1500
Application Level	Class A
Country of Manufacturer	China
Fire Safety Class	Class C according to ANSI/UL 1703-2018

ELECTRICAL PARAMETERS AT STC

Module Name	LP182*182-M-54-MH-410W	LP182*182-M-54-MH-415W
Power	410W±3%	415W±3%
Open Circuit Voltage	37.34V±5%	37.54V±5%
Short Circuit Current	13.70A±5%	13.75A±5%
Maximum Power Voltage	31.22V	31.62V
Maximum Power Current	13.06A	13.12A
Module Efficiency	20.97%	21.23%

* Under Standard Test Conditions (STC) of irradiance of 1000 W/m², spectrum AM 1.5 and cell temperature of 25°C.

ELECTRICAL PARAMETERS AT NMOT

Power	302W	306W
Open Circuit Voltage	34.89V	35.09V
Short Circuit Current	10.80A	11.00A
Maximum Power Voltage	29.18V	29.38V
Maximum Power Current	10.35A	10.40A
Module Efficiency	15.45%	15.65%

* Under Nominal Module Operating Temperature (NMOT), irradiance of 800 W/m², spectrum AM 1.5, ambient temperature 20°C, wind speed 1 m/s.

TEMPERATURE CHARACTERISTICS

NMOT	41±3°C	Temp Coefficient of ISC	+0.05%/°C
Temp Coefficient of VOC	-0.28%/°C	Temp Coefficient of Pmax	-0.36%/°C

PACKING CONFIGURATION

Modules/Pallet	36 Pieces	Modules/40'Container	936 Pieces
Packing Description	26 Pallets, Total=(36+36)x13=936 Pieces		

CHARACTERISTICS

LP182*182-M-54-MH-410W

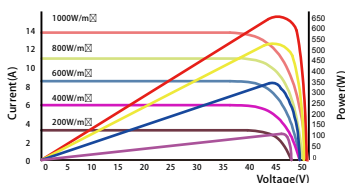

LP182*182-M-54-MH-410W

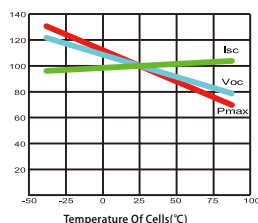

MAXIMUM RATING

Output Tolerance	±3%
Operating Temperature	-40°C~+85°C
Wind Load/Snow Load	2400pa/5400pa
Fuse Current	15A

25 YEARS Product Warranty

25 YEARS Power Warranty