

Sigma S1

Installation Manual

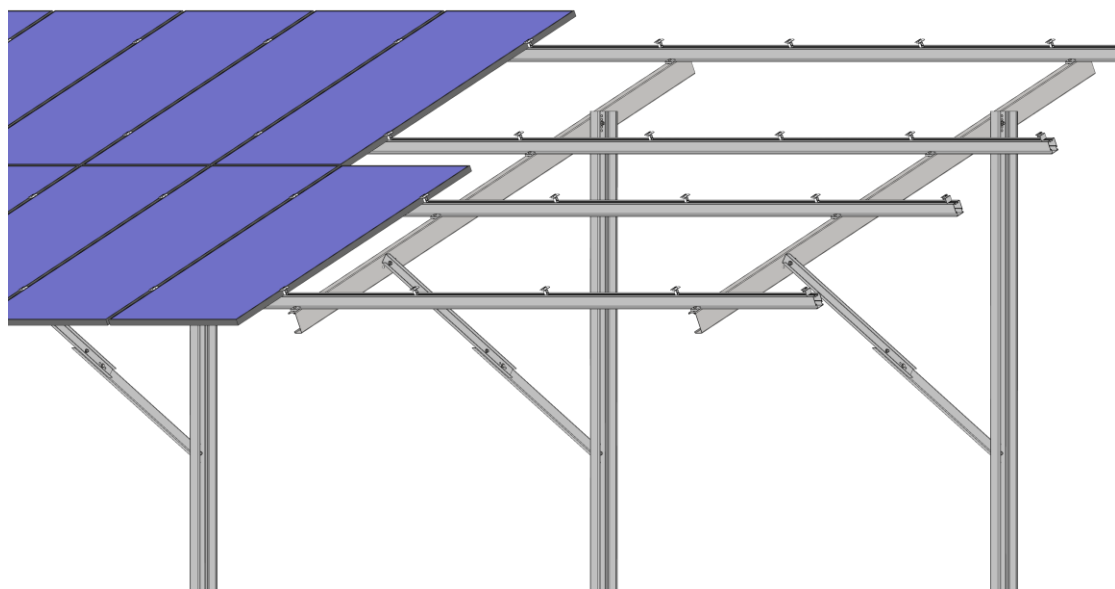

Contents:

1	Introduction	
1.1	Description	1
1.2	About the Manual	1
1.3	Warnings	2
1.4	Safety	2
2	Technical Description	
2.1	System Overview	3
2.2	Component Details	4
2.3	Module Clamps	5
3	Project Drawing and Bill of Materials	6
4	Basic Installation Requirements	
4.1	System Units	6
4.2	Required Tools	6
4.3	Tightening Torques	6
5	Foundation	7
6	Support Assembly	8
7	Purlin Installation	9
7.1	Purlin Placing and Alignment	9
7.2	Purlin Connector	9
8	Module Clamp Installation	10
9	Module Installation	
9.1	Framed Modules – Portrait	11
9.2	Framed Modules – Landscape	12
9.3	Frameless Modules – Portrait	13
9.4	Frameless Modules – Landscape	13
10	Maintenance	
10.1	Inspection	14
10.2	Testing	14

1. Introduction

1.1. Description

The Sigma S1 is a single post PV ground mount system that allows for flexible arrangement of modules in either portrait or landscape orientation and can be installed by means of driven piles.

1.2. About the Manual

Content

These instructions provide important information regarding system, components, planning and safety warnings when handling the Sigma S1.

Sections 1, 2 and 3 show an overview as well as detailed information about the Sigma S1 and its components. Section 4 provides the basic planning information. The remaining sections provide detailed system assembly and installation instructions.

Installation Manual Validity

This installation manual is only valid in conjunction with:

- S-Rack Australia Pty Ltd's Terms and Conditions. This document applies to all contracts and agreements for all products and services offered by S-Rack Australia Pty Ltd.
- The Project Specific Drawings. These documents show all the project specific installation details, choice of components, dimensions and any deviation from the standard material/assembly. Therefore, these drawings take precedence over the installation manual in case of discrepancies between the two documents.
- The supplied material for the Sigma S1 according to the Bill of Materials (BOM).

The content of these documents must be followed during installation for the S-Rack Australia Pty Ltd warranty to apply.

Please read and check the Installation Manual, Project Drawings and Bill of Materials carefully prior to any installation, maintenance, and disassembly work.

All necessary information regarding installation, maintenance and disassembly will be provided. If you have any questions after having read these documents, please contact S-Rack Australia Pty Ltd.

Target Group

Skilled and trained personnel.

Skilled/Trained Personnel

An individual who has acquired professional training and as such, capable of executing installation, maintenance and disassembly work properly.

Guidance Notes

Please see below installation guidance notes.

Symbols:



Important information and useful tips



Additional information and hints to make the installation process easier

1.3. Warnings

The following are used in the installation manual to indicate safety-related information. These include:

- Warning Symbols
- Signal words which identify the hazard level
- Information about the type and source of the hazard
- Information about the potential consequences if the hazard is disregarded
- Measures to prevent injuries and damage to property

The signal words of the warnings respectively indicate one of the following hazard levels:

	Indicates a potentially fatal danger which may result in death or serious injury if ignored.
DANGER	
	Indicates a potentially dangerous situation which may result in serious injury or damage to property if ignored.
WARNING	
	Indicates a potentially dangerous situation which may result in injuries or damage to property if ignored.
CAUTION	
	Indicates potential danger which can result in damage to property if ignored
ATTENTION	

1.4. Safety

Safety instructions for S-Rack Australia Pty Ltd products are included in the documents. Do not use the products in a manner other than its intended function.

It is the responsibility of the customer to ensure that all general and specific safety instructions are followed.

In addition, please observe the specific safety instructions provided in this Installation Manual for all installation work. The specific safety instructions are positioned in each case directly with the respective installation steps.

2. Technical Description

This section provides a breakdown of the Sigma S1 and its components. Upon delivery of the system, check to ensure that all parts and components adhere to the BOM and project specific drawings. Any items missing or damaged must be notified to S-Rack Australia Pty Ltd immediately.

2.1. System Overview

An overview of the Sigma S1 system can be seen below (Image 2.1-1). Please note that some components can vary depending on project-specific requirements.

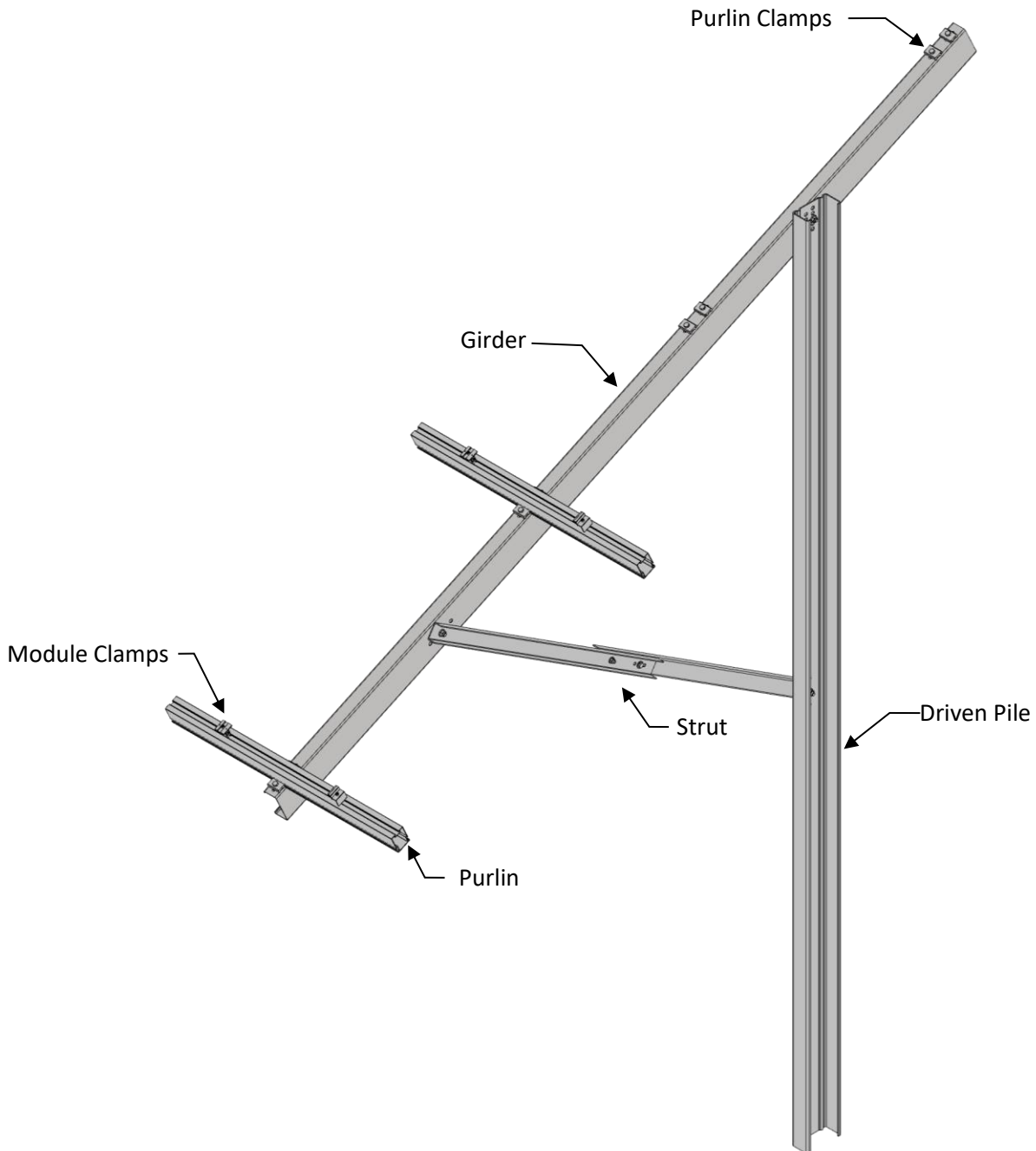

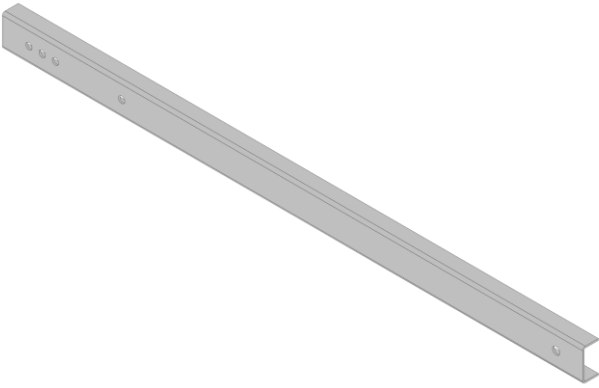
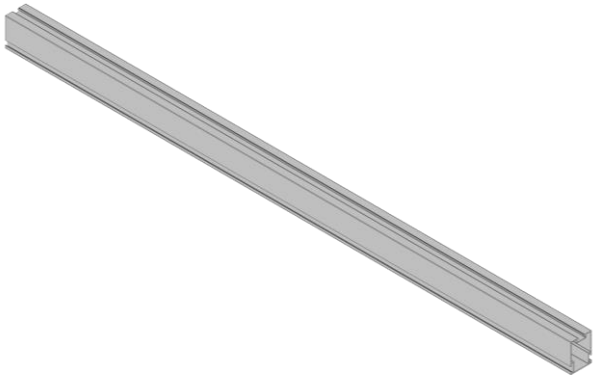
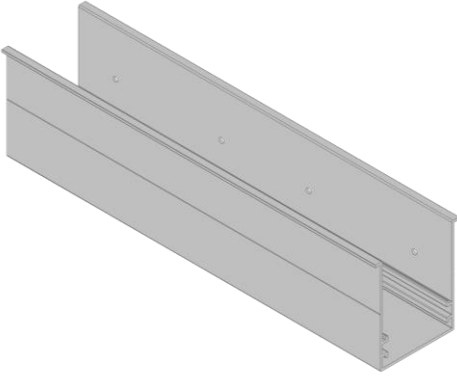
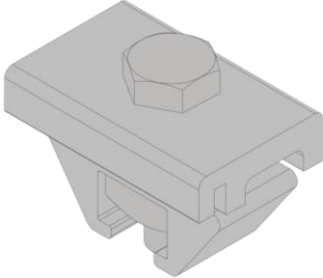

Image 2.1-1 - System Overview of the Sigma S1 System

2.2. Component Details

Overview of System Components	
 <p>Foundation</p>	 <p>Girder</p>
 <p>Strut</p>	 <p>Purlin</p>
 <p>Purlin Connector</p>	 <p>Purlin Clamp with Cage Nut</p>

2.3. Module Clamps

Module Clamps are used to secure the PV modules to the Sigma S1 purlins. Module clamps are equipped with a clickstone, while laminate clamps use a T-head bolt to install the module clamps into the Sigma S1 purlins.

Module End Clamp

These clamps are installed at the start and end of a PV module row. These clamps are available in discrete sizes allowing it to precisely match the required PV module thickness.

Module Mid Clamp

These clamps are installed in-between PV modules along a PV module row and can be integrated with grounding pins.

Laminate Mid/End Clamps

Laminate module clamps allow frameless modules to be mounted without applying too much pressure on the modules.

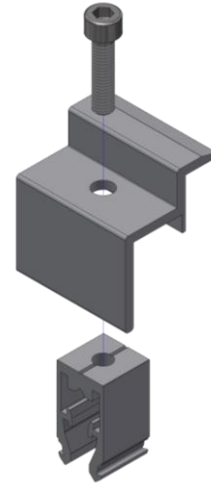

Image 2.3 – 2 Module End Clamp

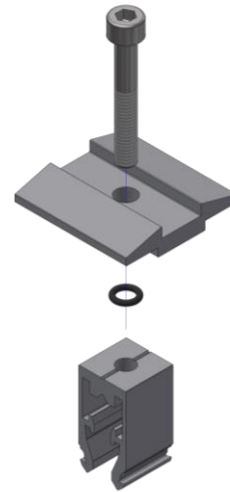

Image 2.3 – 1 Module Clamps



Image 2.3 – 4 Laminate Mid Clamp



Image 2.3 – 5 Laminate End Clamp

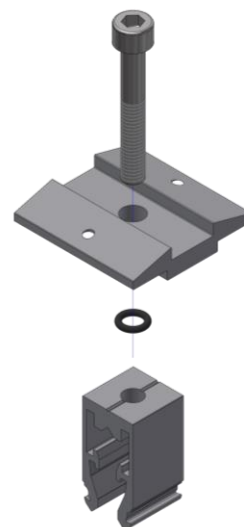

Image 2.3 – 3 Module Mid Clamp with Grounding Pins

3. Project Drawings and Bill of Materials

Project-specific documentation is supplied as part of the Sigma S1. These documents contain all the information necessary to install the system.

The documentation includes:

- Bill of Materials
- Project Drawings (s) which show:
 - Exact module configuration for the project
 - Specific foundation information for the project
 - Dimensions and tolerances

4. Basic Installation Requirements

4.1. System Units

The Sigma S1 is designed in separate system units which can be up to 30m long (without expansion gaps). Please refer to the BOM and Project Drawings for the dimensions of a specific system unit.

4.2. Required Tools

In order to mount the Sigma S1, the following tools are required:

- Power drill/electric screwdriver
- Folding rule/measuring tape
- Angle measuring tool (protractor)
- Spirit level or laser level tool
- M6 Allen key for module clamps
- M8 Allen key for laminate module clamps
- Wrenches for M10 and M12 bolts

4.3. Tightening Torques

A good quality torque wrench should be used to tighten bolted connections to the torque requirements below.

Connection	Size	Nm
Piles, girder, and struts	M12	40
Purlin clamps and cage nut	M10	30
Laminate module clamps	M8	15
Module clamps	M6	10

5. Foundation

Driven piles should be oriented as shown in Image 5.1 -1. Make sure that the posts are positioned and installed within the tolerances. The corresponding tolerances will be specified in the project drawings.

Note:

As an alternative to ramming, piles can also be encased in concrete / stabilised sand. Refer to project documentations for specific dimensions and requirements.

Tolerances

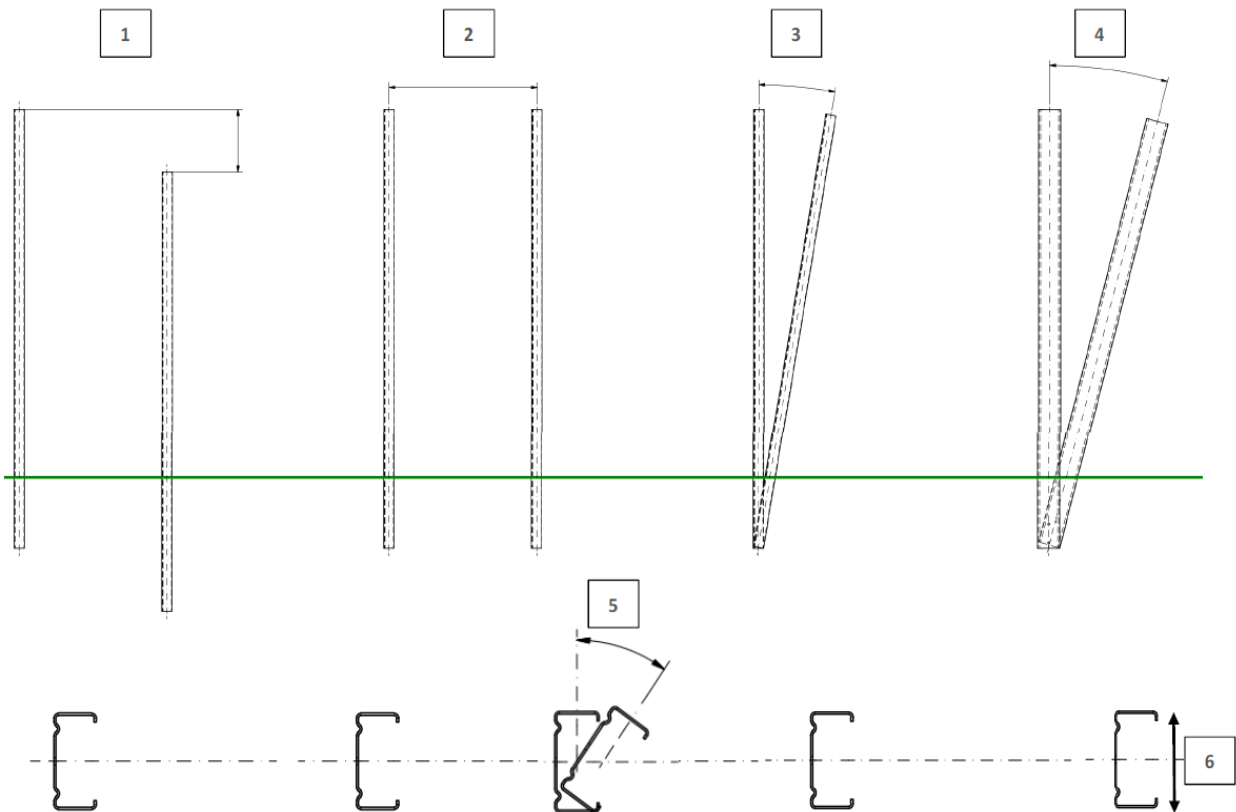

Image 5.1 – 1 Orientation of Driven Piles

In the absence of specific information in the drawings, the following guidelines apply:

1. Post height max. ± 2 cm based on planned height
2. Position E-W max. ± 5 cm, Position N-S max. ± 2 cm
3. Inclination tolerance E-W max. 2° ($1^\circ \approx 2\text{cm/m}$)
4. Inclination tolerance N-S max. 2°
5. Torsion max. 2°
6. Axis tolerance E-W max. $\pm 2\text{cm}$ based on the post top



Hint!

After the ramming posts have been set, the pile head (about 3cm) should be treated with a zinc dust primer. This prevents premature corrosion and thus support the longevity of the system.

6. Support Assembly

Installation Steps

Connect the girder (pre-assembled with purlin clamps), strut (pre-assembled) and pile together as shown in (Image 6.1). Please refer to the Project Drawings and BOM for the correct type, positioning and small parts used for the connections. Make sure to observe the right tightening torques.

Note:

Depending on project specifications, an additional strut may be required. Refer to the project-specific drawings.

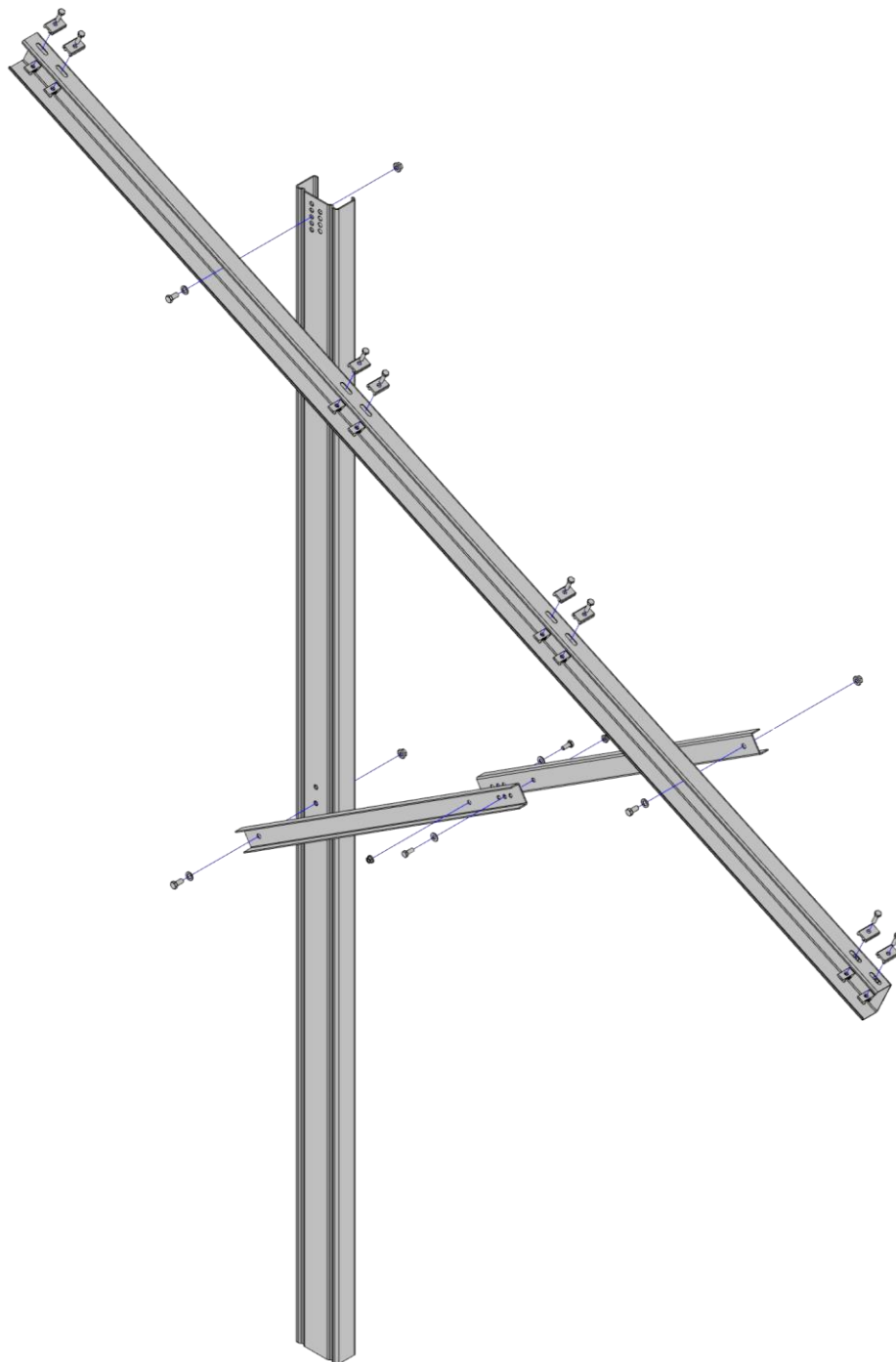

Image 6.1 General Structure of the Sigma S1 Support

7. Purlin Installation

The Sigma S1 System uses purlins mounted on the girder to hold the modules in place. Purlin clamps are used to secure the purlins to the girder.

Note:

Depending on project specifications, additional purlins may be required. Refer to the project-specific drawings.

7.1. Purlin Placing and Alignment

Installation Steps

1. Position the purlins horizontally on top of the rafters and align them. Please refer to the project drawings for the exact position of the purlins with regards to:
 - Spacing between purlins
 - Horizontal overhang (cantilever) over the outer driven piles
2. Loosen the purlin clamps pre-assembled into the girder. Clamp both sides of the purlin to the purlin clamps.
3. Check that the spacing of the purlins does not get shifted with the final tightening of the bolts. Readjust if necessary.
4. Adhere to the specified tightening torques

7.2. Purlin Connector

The purlins are spliced together using a purlin connector.

Mounting Steps

1. Slide the purlin connector halfway into the installed purlin. Secure the connector to the purlin by drilling 2 self-tapping screws into the pre-drilled holes in the connector.
2. Slide the next purlin into the connector leaving no gaps between the 2 purlins. Secure the 2nd purlin by drilling another 2 self-tapping screws into the pre-drilled holes in the connector.
3. Adhere to specified tightening torques.

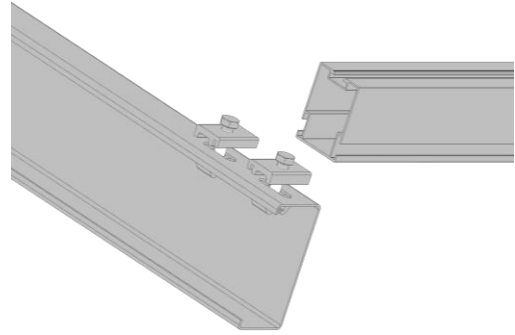

Image 7.1-1 Installing the Purlins

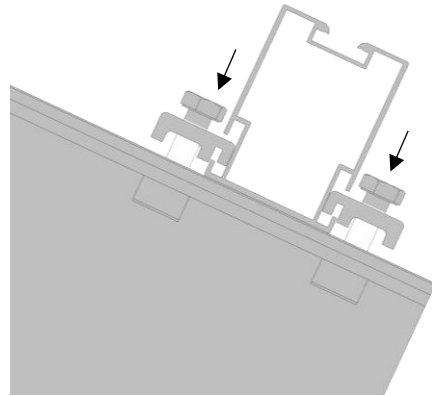

Image 7.1-2 Mounting the Purlins

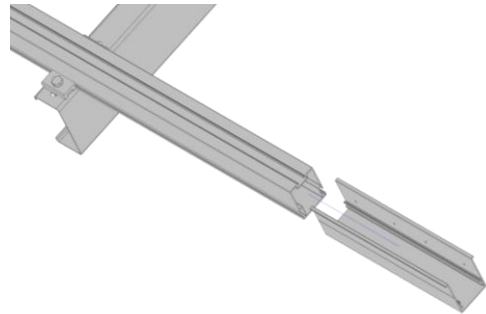

Image 7.2-1 Installing the Purlin Connector

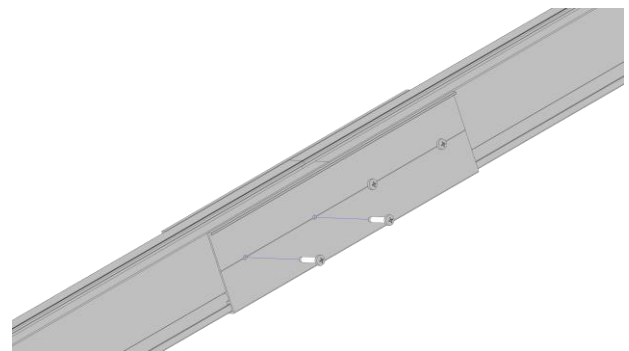

Image 7.2-2 Connecting 2 Purlins

8. Module Clamp Installation

For framed modules, the module clamps for the Sigma S1 uses a clickstone to attach the module clamps to the purlin. The module clamps are inserted into the top channel of the purlin and tightened using an Allen key.

For frameless modules, laminate clamps use a T-head bolt inserted into the top channel of the purlin.

Installation Steps

1. Before installing the module clamps, loosen the bolt such that bottom part of the bolt is above the noses of the clickstone.
2. For module clamps, insert the module clamps at a slight angle into the top channel of the purlin. While holding it firmly, rock the clickstone upright until it clicks into place.
3. For laminate clamps, align and insert the T-head bolt into the top channel of the purlin.
4. Tighten the clamps using the recommended torque settings.



Hint!

The clickstone is made undersized so that it is easy to lock it in the module rail channel. By tightening the screw, the clickstone is forced apart ensuring the right support.

To remove the clickstone, loosen the screw until it no longer touches the noses in the click stone, press the legs of the clickstone together, tilt at an angle, then remove it from the channel.



CAUTION

Material damage due to incorrect installation

Incorrectly mounted module clamps can cause the PV modules to fall and be damaged.

Mount all module clamps in accordance with the instructions.

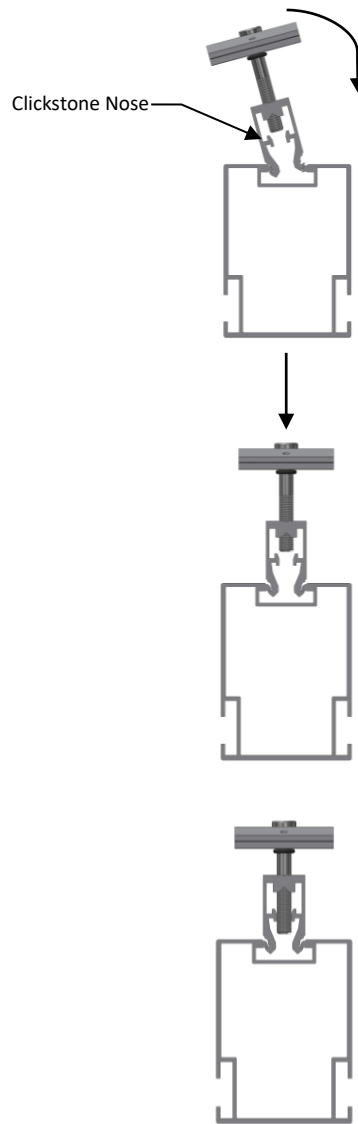

Image 7 – 1 Module Clamp Installation

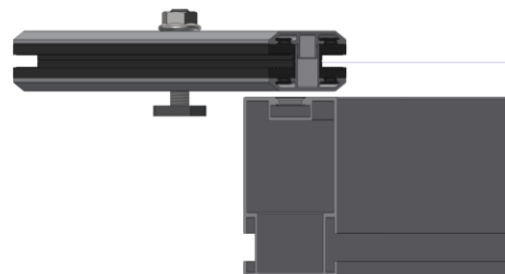

Image 7 – 2 Laminate Clamp Installation

9. Module Installation

The procedure below describes the installation of modules on a single row. This procedure can begin on the west end of the array moving east or vice-versa.

9.1. Framed Modules – Portrait

1. Insert a module end clamp into each purlin.
2. Place the first PV module on the purlin and slide the module frame against the end clamp. With the module's clamping points correctly positioned under the end clamps, tighten the end clamps onto the module frame.
3. Insert a mid clamp into each the purlin. Push it flush against the module, ensuring the clamp body rests on top of the previously installed module frame. Place the next module on the purlin and slide it against the mid clamps.
4. Repeat the above steps for the rest of the row of modules. At the end of a row, install an end clamp on the outside of the last module to complete the row.

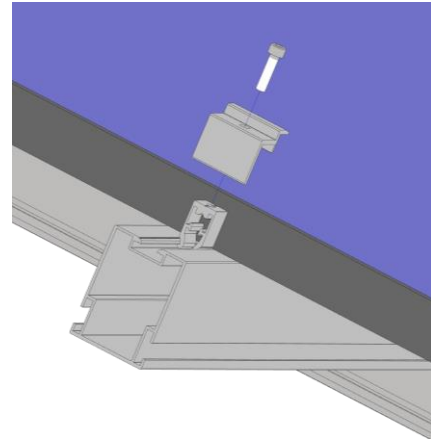

Image 9.1 – 1 Module End Clamp

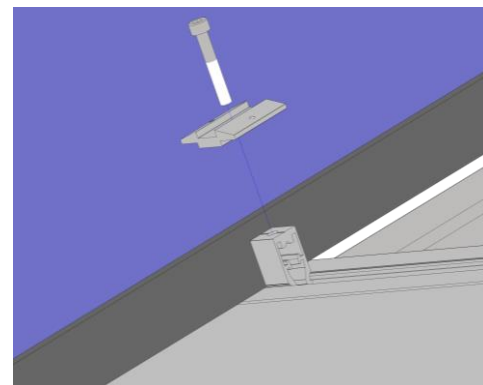

Image 9.1 – 2 Module Mid Clamp

Hint!



Use of a spare module clamp or other item as a spacing gauge between the modules columns ensures that the spaces between columns are the same.

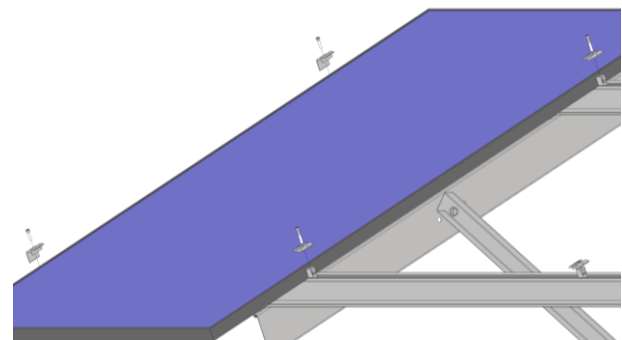

Image 9.1 – 3 Portrait Installation

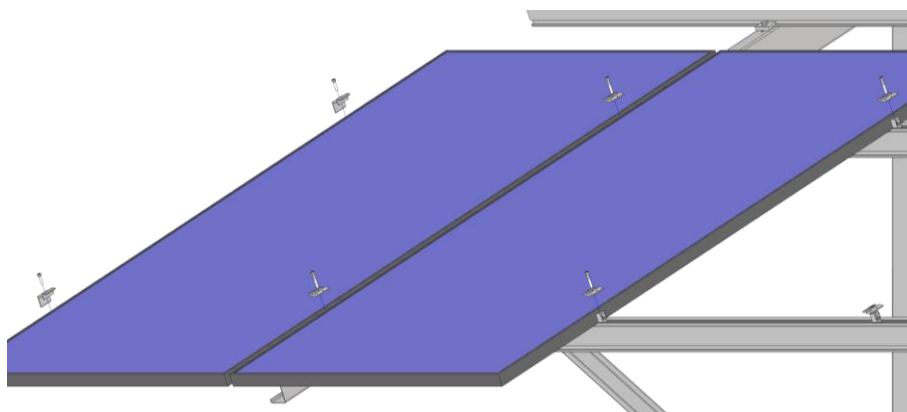

Image 9.1 – 4 Placing the next PV module

9.2. Framed Modules – Landscape

1. Insert a module end clamp into the bottom purlin.
2. Place the first PV module on the bottom purlin and slide the module frame against the end clamp. With the module's clamping points correctly positioned under the end clamps, tighten the end clamps onto the module frame.
3. Insert a mid clamp into the next purlin. Push it flush against the module, ensuring the clamp body rests on the previously installed module frame. Place the next module onto the next purlin and slide it against the installed mid clamp.
4. Repeat the above steps until the top rail is reached. At the topmost purlin, install an end clamp on the outside of the last module to complete the column.

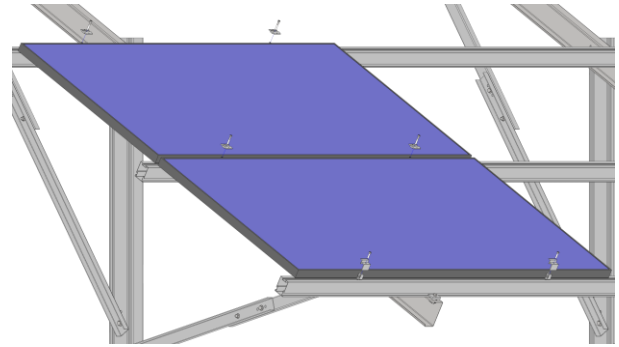

Image 9.2 – 1 Landscape Installation

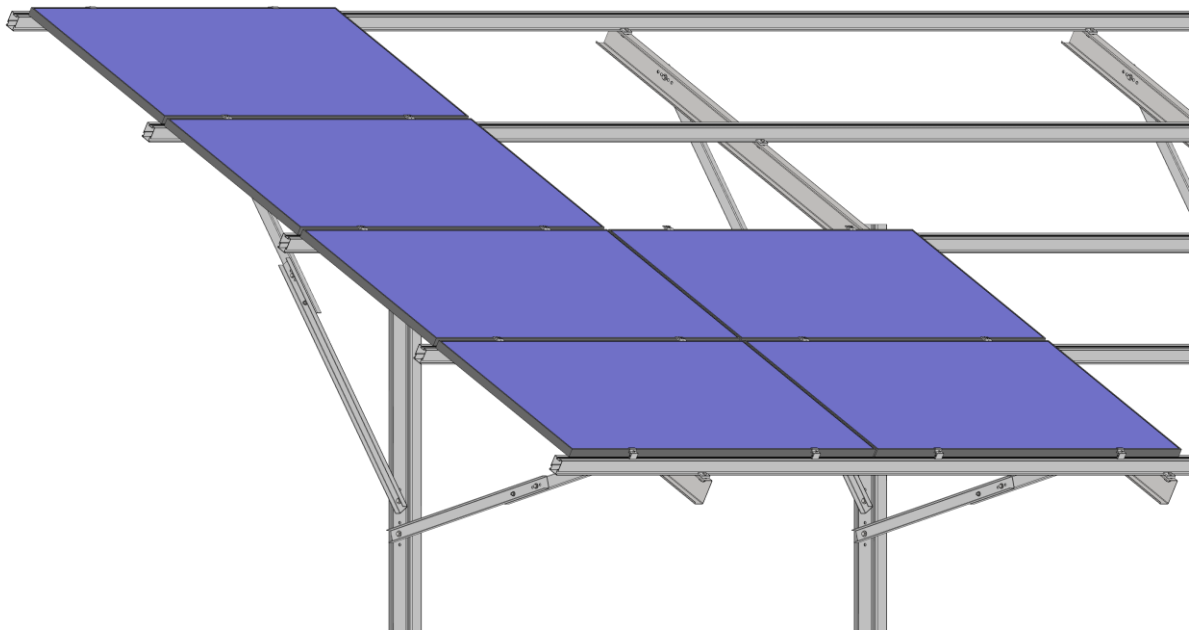

Image 9.2 – 2 Installing next column of modules

9.3. Frameless Modules – Portrait

1. Insert a laminate end clamp into the purlins.
2. Place the frameless module on the purlin and insert it into the laminate end clamp leaving at least a 1mm gap.
3. Insert a laminate mid clamp into the previously installed module. Place the next module on the purlin and insert it on the installed laminate mid clamp. When inserting the modules into the laminate mid clamp, remember to leave at least a 1 mm gap.
4. With the module's clamping points correctly aligned with the laminate clamps, tighten the clamp to the module.
5. Repeat the above steps for the rest of the row of modules. At the end of the row, install a laminate end clamp on the outside of the last module to complete the row.

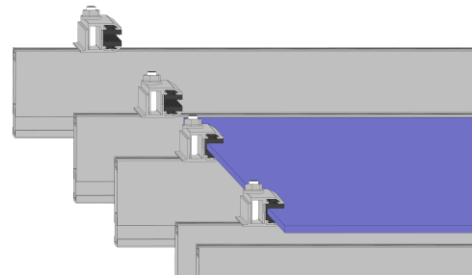

Image 9.3 – 1 Laminate End Clamps in Portrait

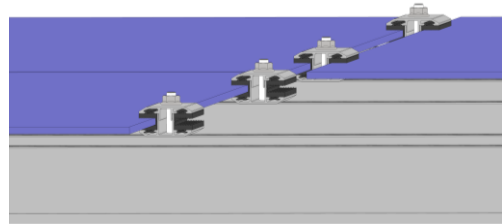

Image 9.3 – 2 Laminate Mid Clamps in Portrait

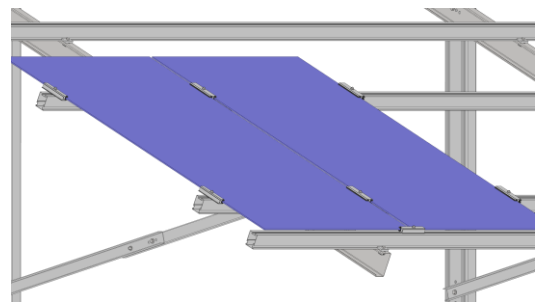

Image 9.3 – 3 Portrait Installation

9.4. Frameless Modules – Landscape

1. Insert a laminate end clamp into the bottom purlin. Place the frameless module on the purlin and insert it into the laminate end clamp leaving a 1mm gap.
2. Insert a laminate mid clamp into the next purlin and insert the installed module into it. Install the next module by inserting it to the installed laminate mid clamp. When inserting the modules into the laminate mid clamp, remember to leave at least a 1mm gap.
3. With the module's clamping points correctly aligned with the laminate clamps, tighten the clamp to the modules
4. Repeat the above steps until the topmost purlin is reached. At the end of the column, install a laminate end clamp on the outside of the last module to complete a column.
5. Repeat steps 1-4 to install another column of modules.

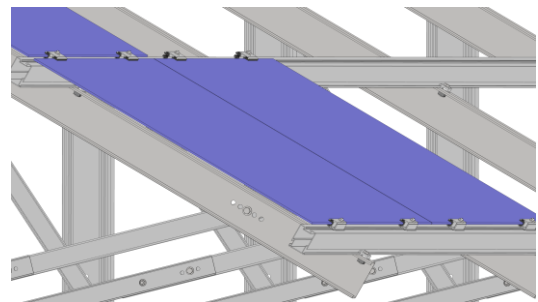

Image 9.4 – 1 Laminate Clamps in Landscape

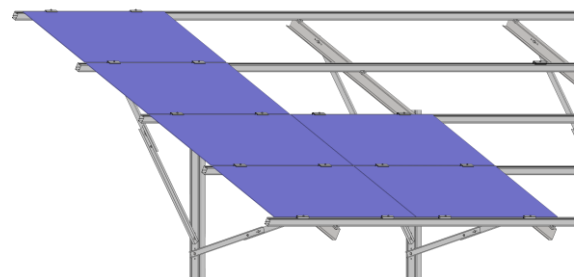

Image 9.4 – 2 Installing next column of modules

10. Maintenance

When properly assembled, the Sigma S1 is a reliable and trouble-free system that requires minimal maintenance. Nevertheless, S-Rack Australia Pty Ltd recommends performing regular inspections and creating a maintenance schedule. By doing so, potential problems can be detected and resolved before they can become serious, ensuring the system's excellent long-term durability and reliability.

The following procedure pertains only to the Sigma S1 System structure. Maintenance and repair of other PV system components should be carried out in accordance with the respective manufacturers' recommendations.

9.1. Inspection

The system should be visually inspected for obvious loose connections, missing components, modules which appear to have shifted, vegetation overgrowth, wind-blown debris, and other indications of abnormality annually. Any problems detected at this time should be addressed and repaired as necessary.

9.2. Testing

After one year in service, it is good practice to check the torque settings of a representative sample of system connections including module clamps and rail clamps. Do not exceed the recommended torque settings. If a disproportionate number of loose connections (more than 10% of connections) are found, it may be an indication of an improper assembly and it may be necessary to take comprehensive corrective action.

S-Rack Australia Pty Ltd recommends keeping records of connections sampled each year and checking untested connections in the succeeding years. Once all connections have been tested, sample sizes and test frequency can be reduced.

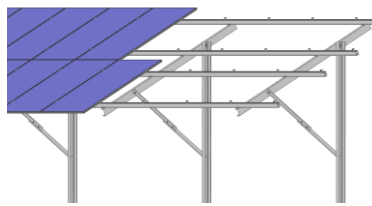

S-Rack Australia Pty Ltd
Suite W3B4, 75 O'Riordan Street
Sydney Corporate Park
Alexandria 2015
NSW

Tel: (02) 89 993 830
Fax: (02) 89 993 835

info@s-rack.com.au

Subject to technical alterations
2021 © S-Rack Australia Pty Ltd

Ver. Date: 28/01/2021